

➤ **Features ver1.07**

Positive Voltage Control  
 1dB Steps, Maximum Attenuation 31dB  
 MSOP—10 Package  
 Meet RoHS Standard

➤ **Description**

SS109 is a GaAs MMIC 5 bits digital control attenuator. 0.5dB steps, maximum attenuation 31 dB. With the features of low power loss, low insertion loss, in the positive control voltage 0V/3~5V, easy to use. It is adapt to various telecommunications including mobile phone GSM/CDMA base station and wireless LAN etc.

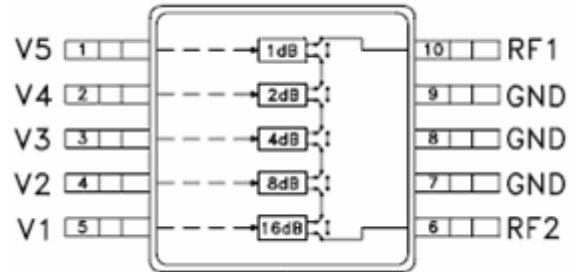

➤ **Typical Electrical Specification at 25°C**

Characteristic		Frequency	Min.	Typ.	Max.	Unit
Insertion Loss		0.5-1.0 GHz		2.0	2.5	dB
		1.0-1.5GHz		2.5	3.0	dB
		1.5-2.0 GHz		2.8	3.0	dB
		2.0-2.5 GHz		3.0	3.5	dB
VSWR		0.5-2.5 GHz		1.5	1.8	
Attenuation Precision		0.5-1.0 GHz	± (0.3+3% of Attenuation Setting in dB)			dB
		1.0-1.5GHz	± (0.3+5% of Attenuation Setting in dB)			dB
		1.5-2.0 GHz	± (0.5+5% of Attenuation Setting in dB)			dB
		2.0-2.5 GHz	± (0.8+5% of Attenuation Setting in dB)			dB
Switch Characteristic	Rise or Fall (10/90% or 90/10 RF)			600		ns
	On or Off (50%CTL to 10/90% RF)			800		ns
Power Characteristic				27		dBm
Control Voltage	V <sub>low</sub> =0V, V <sub>dd</sub> =3~5V					

1. All measurements in a 50-Ω system, unless otherwise specified
2. Insertion loss state.

➤ Typical Performance Curves

Insertion Loss vs. Frequency

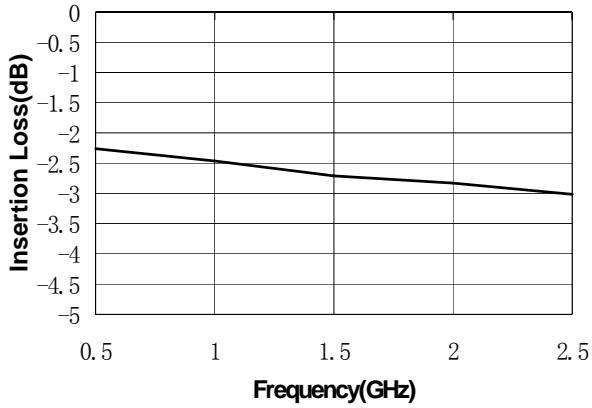

VSWR<sub>in</sub> (Major states) vs. Frequency

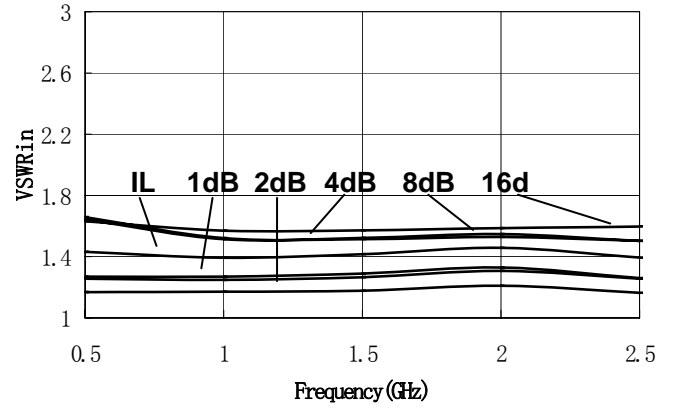

Attenuation vs. Frequency

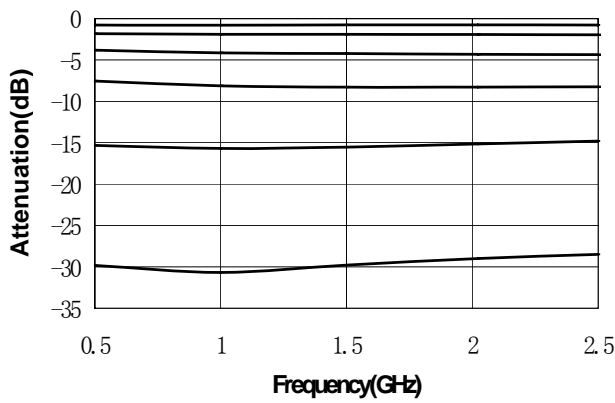

VSWR<sub>out</sub> (Major states) vs. Frequency

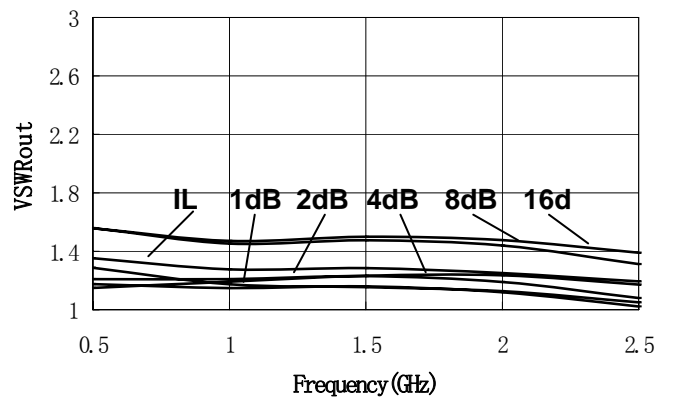

➤ Circuit Application Picture

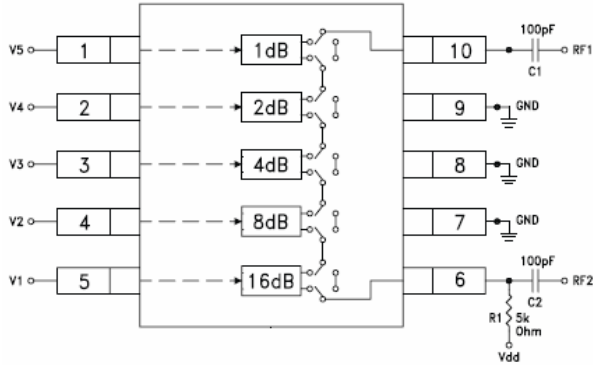

说明:

C1、C2 is a RF blocking capacitor., with the option of 100~300pF capacitor. Direct current Vdd add to 6feet or 10 feet of RF port through resistor R1=5KΩ

➤ MSOP-10 Outline Dimension

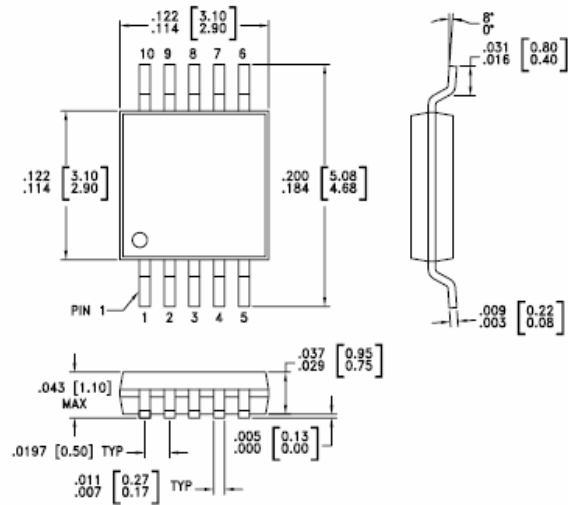

➤ Truth Table

Control Voltage					Attenuation Volume RF1-RF2
V1	V2	V3	V4	V5	
16dB	8dB	4dB	2dB	1dB	Ref. IL
High	High	High	High	High	Ref. IL
High	High	High	High	Low	1dB
High	High	High	Low	High	2dB
High	High	Low	High	High	4dB
High	Low	High	High	High	8dB
Low	High	High	High	High	16dB
Low	Low	Low	Low	Low	31dB

Note:  $V_{low}=0\sim 0.2V @20\mu A Max$   
 $V_{high}=Vdd \pm 0.2V @20\mu A Max$   
 $Vdd=+3V\sim 5V \pm 0.2V$

➤ Absolute Maximum Ratings

Item	Value
Control Voltage (V1-V5)	Vdd+0.5V
Side Voltage Vdd	+8.0V
Operation Temperature	-40°C~+85°C
Storage Temperature	-65°C~+150°C
RF Input Power	28dBm

1. Operation of this device above any one of these parameters may cause permanent damage