

➤ **Features ver1.0**

- 4 Digit Programmable Delay Circuit
- Max Delay Control 1000ps
- Similar Circuit Function with MC10E195
- Can Extend Control Code's Digit and Total Delay Time

➤ **Description**

Programmable delay circuit implement max 1000ps delay control by using 4 digit delay control program. It is used in the clock's deflection and time's regulation of high speed clock. If customer has some special requirements, we can extend the control code's digits and total delay time. This circuit is similar with MC10E195. We will develop the relevant TTL, LVDS input and output ports according to customers' requirements as soon as possible.

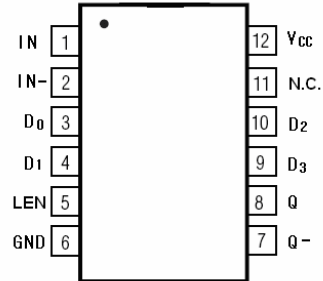

➤ **Circuit Elements Picture**

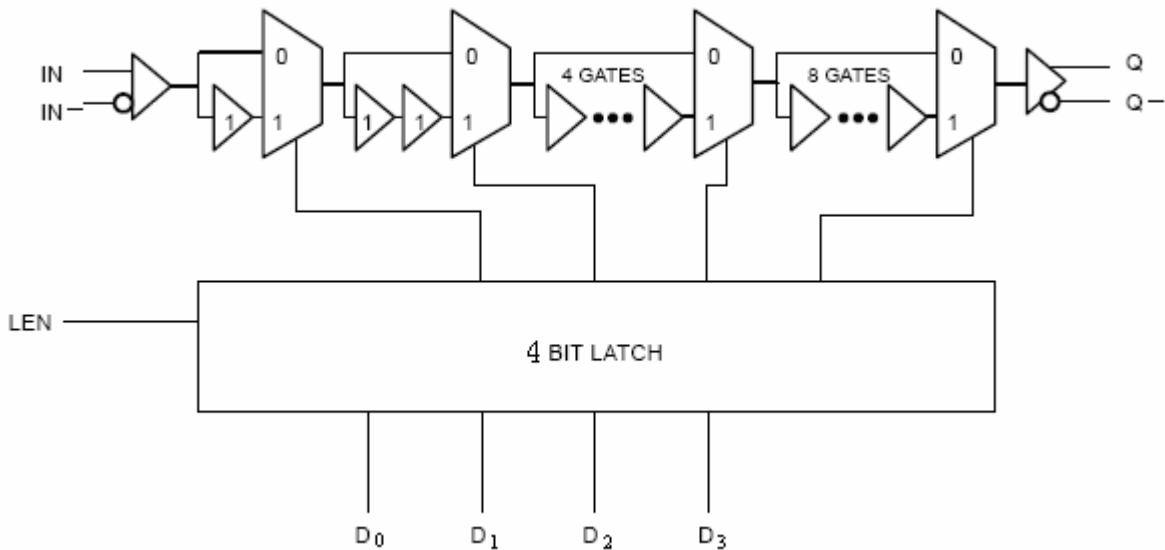

Different transfer path for input signal through make coding for D₀~D₃ makes different delay.

➤ Typical Electrical Specification at 25°C

| Characteristic | Min. | Typ. | Max. | Unit |
|---|------|------|------|------|
| Top Working Frequency | | >6 | | GHz |
| When D ₃ D ₂ D ₁ D ₀ =0000, Delay | 415 | 421 | 454 | ps |
| When D ₃ D ₂ D ₁ D ₀ =1111, Delay | 1457 | 1481 | 1492 | ps |
| When D ₀ =1, Delay step | 55 | 60 | 64 | ps |
| When D ₁ =1, Delay step | 119 | 130 | 133 | ps |
| When D ₂ =1, Delay step | 276 | 280 | 287 | ps |
| When D ₃ =1, Delay Step | 564 | 570 | 577 | ps |
| Rise (20%~80%) | | 37 | | ps |
| Fall (20%~80%) | | 29 | | ps |
| Output Signal Peak Value | | 2400 | | mV |
| Space Oppupancy Excursion | | ±24 | | ps |

1. The standard power voltage of the chip is 3.3 V, input is defferent signal, peak value(Typical_) is 400mV。
2. The data in the above table is according to the situation when input is sine wave, frequency is 2GHz, peak value is 400mV.

➤ Typical Electrical Specification at 0°C

| Characteristic | Min. | Typ. | Max. | Unit |
|---|------|------|------|------|
| When D ₃ D ₂ D ₁ D ₀ =0000, delay | 409 | 420 | 447 | ps |
| When D ₃ D ₂ D ₁ D ₀ =1111, delay | 1449 | 1462 | 1476 | ps |
| When D ₀ =1, delay | 53 | 59 | 64 | ps |
| When D ₁ =1, delay step | 119 | 129 | 134 | ps |
| When D ₂ =1, delay step | 274 | 280 | 287 | ps |
| When D ₃ =1, delay step | 560 | 565 | 574 | ps |
| Rise(20%~80%) | | 37 | | ps |
| Fall (20%~80%) | | 25 | | ps |
| Output Signal Peak Value | | 2400 | | mV |
| Space Occuppancy Excursion | | ±21 | | ps |

3. The data in the above table is according to the situation when input is sine wave, frequency is 2GHz, peak value is 400mV.

➤ Typical Electrical Specification at 85°C

| Characteristic | Min. | Typ. | Max. | Unit |
|---|------|------|------|------|
| When D ₃ D ₂ D ₁ D ₀ =0000, delay | 421 | 429 | 459 | ps |
| When D ₃ D ₂ D ₁ D ₀ =1111, delay | 1480 | 1491 | 1523 | ps |
| When D ₀ =1, delay step | 58 | 61 | 69 | ps |
| When D ₁ =1, delay step | 120 | 131 | 139 | ps |
| When D ₂ =1, delay step | 277 | 283 | 296 | ps |
| When D ₃ =1, delay step | 570 | 575 | 590 | ps |
| Rise (20%~80%) | | 38 | | ps |
| Fall (20%~80%) | | 32 | | ps |
| Output Signal Peak Value | | 2200 | | mV |
| Space Occupancy Excursion | | ±31 | | ps |

4. The data in the above table is according to the situation when input is sine wave, frequency is 2GHz, peak value is 400mV.